

UNITED STATES PATENT OFFICE.

CHARLES W. HAYS, OF NEW YORK, N. Y.

MEANS FOR PREVENTING THE ACCUMULATION OF GAS IN MAN-HOLES.

SPECIFICATION forming part of Letters Patent No. 457,436, dated August 11, 1891.

Application filed October 1, 1890. Serial No. 366,738. (No model.)

To all whom it may concern:

Be it known that I, CHARLES W. HAYS, of the city, county, and State of New York, have invented a new and Improved Means
5 for Preventing the Accumulation of Gas, Water, &c., in Man-Holes, of which the following is a full, clear, and exact description.

In the construction of subways for electric wires, pipes, &c., and in the construction of
10 various underground canals—such as sewers—man-holes are arranged at frequent intervals, so as to afford means of communication between the underground ways and the street above. These man-holes are usually
15 provided with a cover at top and bottom, and a great deal of difficulty has been experienced from the fact that explosive gases accumulate in the man-holes, and the man-holes are also likely to collect water, which in the winter-time freezes, and it is then very difficult
20 to open the man-holes.

The object of my invention is to provide means for obviating these difficulties.

To this end my invention consists in the
25 insertion of a removable filling in the man-hole and in a peculiarly-formed vessel and box adapted to serve the purpose of a filling.

This construction will be hereinafter fully described, and then pointed out in the claims.

30 Reference is to be had to the accompanying drawings, forming a part of this specification, in which similar letters of reference indicate corresponding parts in both the figures.

Figure 1 is a sectional view showing an
35 ordinary man-hole and the means of filling it as arranged in accordance with my invention; and Fig. 2 is a detail perspective view of the box or vessel used for filling the man-hole.

The subway A is of the usual construction
40 and has ducts *a* leading to adjacent buildings, the subway being laid in the usual manner beneath the pavement B of a street, and opening from the subway through the pavement is a man-hole C, having a suitable lining D,
45 which carries a ring at the top, of ordinary construction, the ring having on its inner sides a projecting flange *e* to support the cover F of the man-hole. A cover H is also placed in the bottom of the man-hole so as to
50 separate it from the subway A. A box J, which is preferably hollow, as shown, and of

a size to nearly fill the man-hole, is inserted from the top and rests upon the cover H, the box having suitable handles *j* on its upper side, by means of which it may be raised and
55 lowered, and having also a nozzle *J'* and a suitable vent-opening through the top, the vent serving to facilitate the escape of excessive steam when steam or hot water are injected into the box to thaw out the man-
60 hole. The nozzle and vent are usually plugged to prevent gas or water from entering the box, and when the box is to be filled, as described, the plugs are removed. It will thus be seen that the box will so nearly fill the
65 man-hole that it will prevent the accumulation of a large amount of gas, and if water should enter the man-hole and become frozen between the sides of it and the sides of the box, the ice thus formed may be quickly
70 thawed by injecting a jet of steam or a stream of hot water through the nozzle *J'* into the box J. The box may be then removed and the man-hole opened.

To prevent the box from floating as the
75 space in the man-hole becomes filled with water, it is provided with a button *j'*, which is located near one edge and upon the upper surface, and after the box is placed in the man-hole the button is turned so as to extend
80 beneath the ring E; but any suitable device may be employed to prevent the floating of the box.

If desired, the box J may be filled with some
85 substance to give it additional weight, and in carrying out my invention it is not essential that the precise form of box shown should be used, as I claim broadly as my invention the insertion of a box or other hollow vessel into
90 the man-hole for the purpose of filling it.

It is obvious from the foregoing description
95 that my invention may be carried out in connection with all kinds of underground ways having man-holes communicating with the surface of the earth.

If desired, the box J may be made to fit
the lower opening of the man-hole, and in that case the cover H may be dispensed with.

Having thus described my invention, what I claim as new, and desire to secure by Let-
100 ters Patent, is—

1. The combination, with the casings and

covers of a man-hole, of a hollow vessel shaped to fit the man-hole, said vessel having suitable handles and a lateral projection to prevent it from rising, substantially as described.

5 2. The combination, with the casing and sides of a man-hole, of a hollow vessel shaped to fit the man-hole, said vessel having suitable handles and also an inlet nozzle and vent, substantially as described.

10 3. The combination, with the casing and covers of a man-hole, of a removable hollow

body approximately filling the inclosed space, substantially as described.

4. The combination, with the casing and covers of a man-hole, of a removable box provided with an inlet nozzle, substantially as described. 15

CHARLES W. HAYS.

Witnesses:

WARREN B. HUTCHINSON,
C. SEDGWICK.

(No Model.)

C. W. HAYS.

MEANS FOR PREVENTING THE ACCUMULATION OF GAS IN MAN HOLES.

No. 457,436.

Patented Aug. 11, 1891.

Fig. 2.

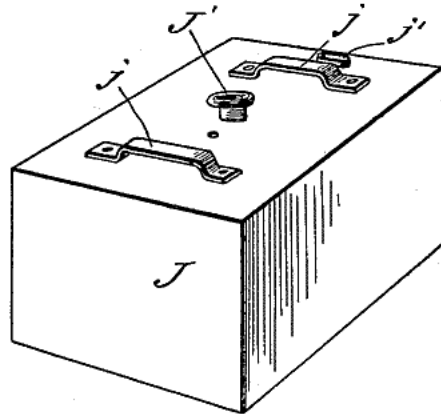
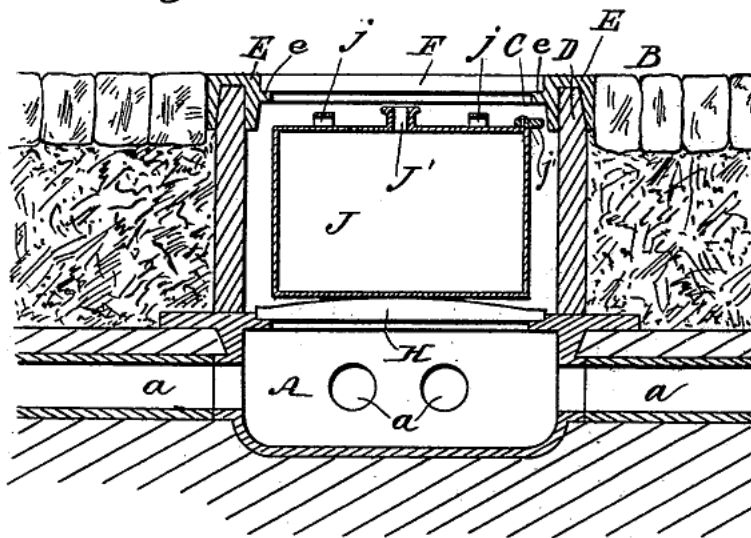

Fig. 1.



WITNESSES:
John M. Deemer
C. Sedgwick

INVENTOR:
C. W. Hays
BY *Munn & Co*
ATTORNEYS