

No. 632,745.

Patented Sept. 12, 1899.

A. PRIESTMAN.
RAISING SEWAGE.

(Application filed June 2, 1899.)

(No Model.)

2 Sheets—Sheet 1.

Fig. 1

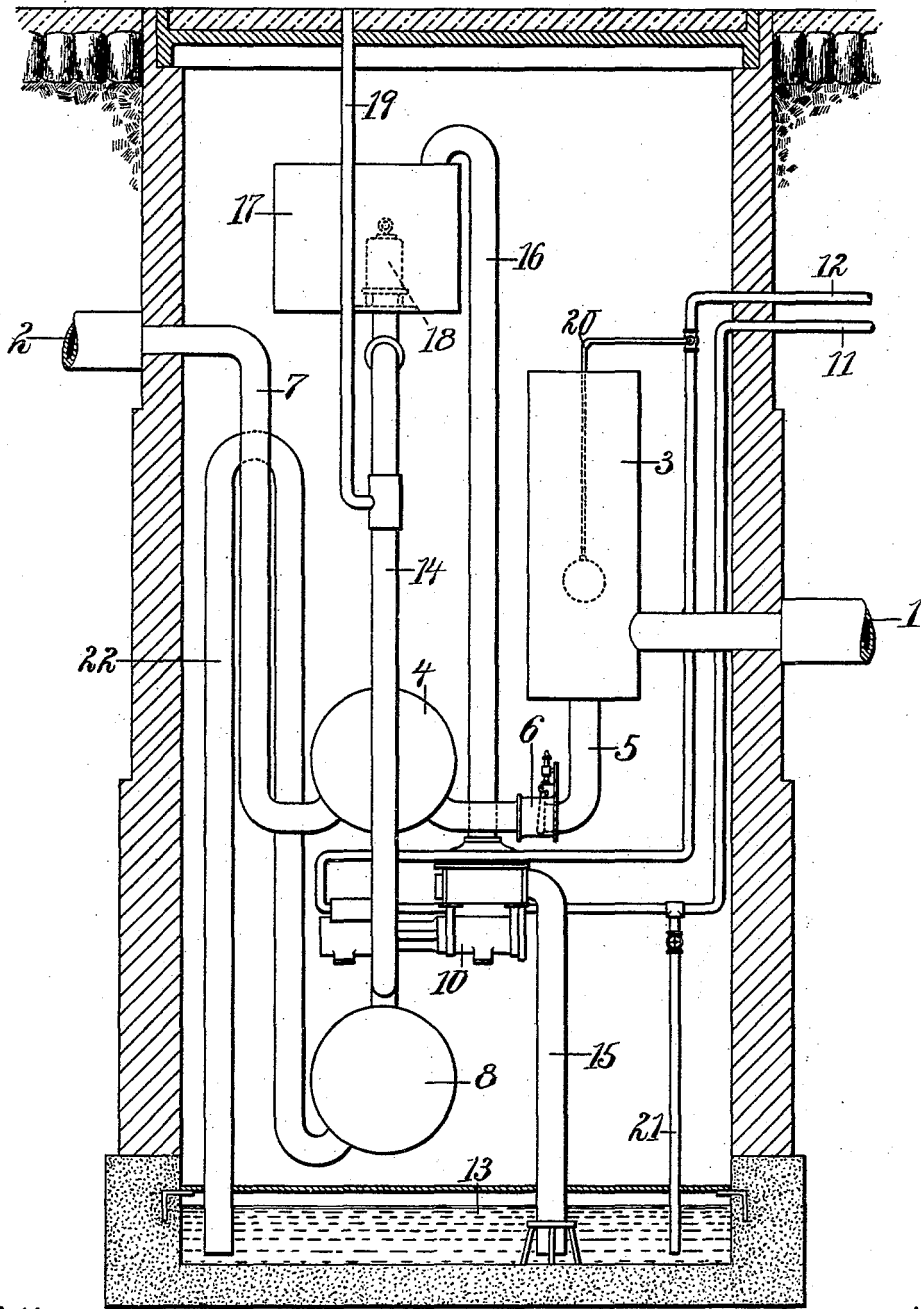

Witnesses:
W. Jackson
K. W. Gilligan

Inventor:
Albert Priestman
By
Augustus B. Skinglin
Attorney

No. 632,745.

Patented Sept. 12, 1899.

A. PRIESTMAN.
RAISING SEWAGE.

(Application filed June 2, 1899.)

(No Model.)

2 Sheets—Sheet 2.

Fig. 2

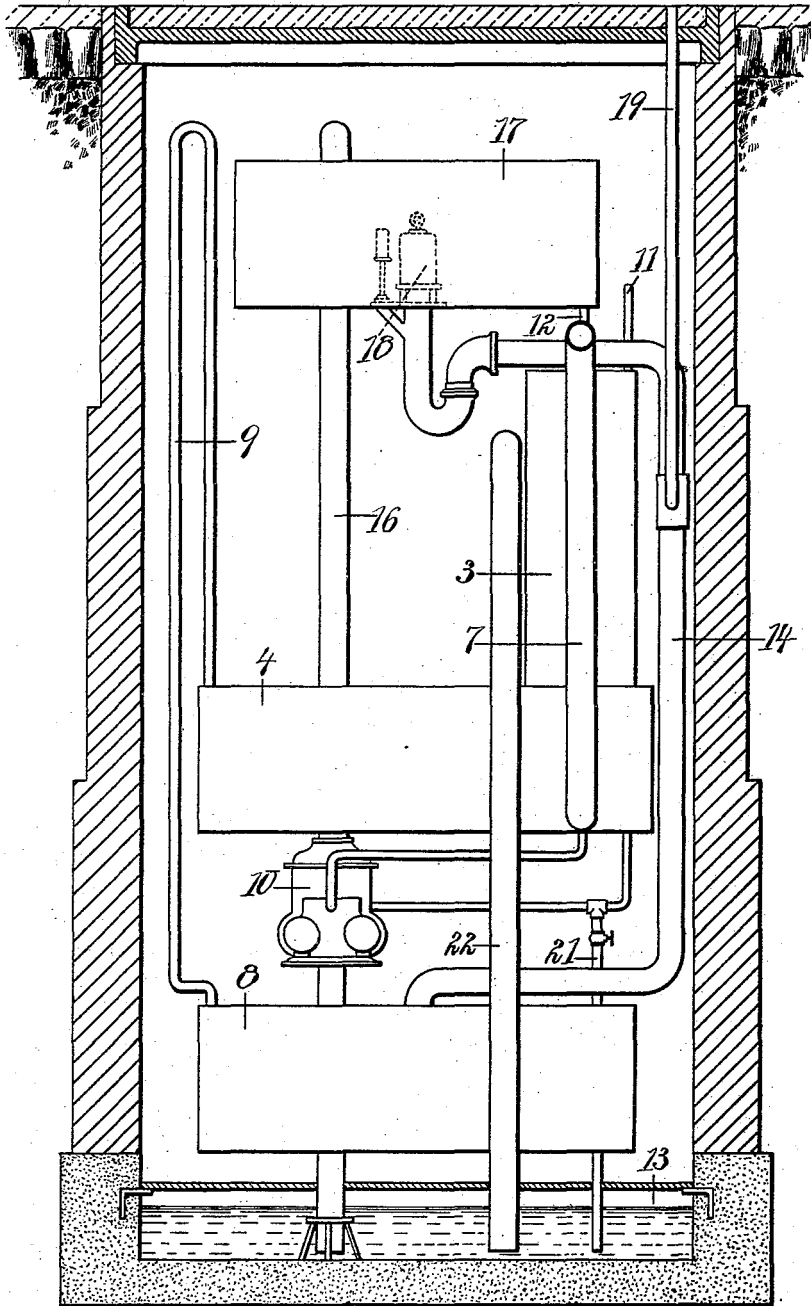

Witnesses:
W. H. Fuessant
E. M. Gilligan

15

Inventor.
Albert Priestman
By
Augustus B. Skough
Attorney

UNITED STATES PATENT OFFICE.

ALBERT PRIESTMAN, OF PHILADELPHIA, PENNSYLVANIA.

RAISING SEWAGE.

SPECIFICATION forming part of Letters Patent No. 632,745, dated September 12, 1899.

Application filed June 2, 1899. Serial No. 719,051. (No model.)

To all whom it may concern:

Be it known that I, ALBERT PRIESTMAN, a subject of Her Majesty the Queen of Great Britain, residing at the city of Philadelphia, in the county of Philadelphia and State of Pennsylvania, have invented certain new and useful Improvements in Raising Sewage and the Like, of which the following is a specification.

10 The economic, practical, and efficient elevation of sewage and the like is a desideratum, but it presents many practical difficulties. One of the most satisfactory and practical systems comprises the use of compressed air as
15 the means for lifting the sewage. The advantages of this system are numerous, and reference may be made to the following: It involves the use of but one check-valve, and the absence of other valves is obviously beneficial.
20 It is rapid in its operation and operates to move the sewage at a high velocity, and thus carry off solids, if present, and it is possible to automatically furnish the supply of compressed air by means of water, and to thus
25 dispense with the services of engineers and air-compressors and make the system commercially practical and economical. In the described system the air for lifting the sewage is set in motion by displacing it with water. Consequently a definite volume of water
30 is necessary for this purpose in each installation. In many localities water is supplied at a comparatively high pressure or head, and in using such supply in connection with such
35 sewage-lifting system it often happens that a considerable portion of the head or pressure of the water-supply is wasted, because, as stated, it is the volume of water employed which is the important factor. To waste the
40 available head or pressure of the water supply, or a material part of it, is not economical and is, in fact, often so expensive as to preclude the use of the most desirable means and methods known for lifting sewage. Heretofore such
45 waste was unavoidable, because, as stated, the volume of high-pressure water used was fixed in each instance by the volume of air to be compressed and used in lifting the sewage. Moreover, the volume of water used for compressing
50 the air after having done its work, at often the expense of a material portion of its head,

was permitted to waste and became somewhat contaminated by contact with the air, which in turn contacted with the sewage.

One object of my invention is to utilize all 55 of the energy of even a high-pressure water-supply for furnishing the necessary air or compressible fluid-pressure for actuating the sewage-lifting apparatus.

To this and other ends my invention, stated 60 in general terms, comprises the transformation of potential energy, as of a comparatively small volume of water at a comparatively high pressure or head, into the energy of a comparatively large volume of water at 65 a lower and appropriate head, and the application and continued reuse of this comparatively large quantity of water for creating air or compressible fluid-pressure, which in turn operates to lift the sewage. 70

The nature, characteristic features, and scope of my invention will be more fully understood from the following description, taken in connection with the accompanying drawings, forming part hereof, and in which— 75

Figure 1 is a transverse sectional view illustrating apparatus embodying features of my invention, and Fig. 2 is a similar view taken in a plane at right angles to the plane of Fig. 1.

In the drawings, 1 represents an intake for 80 sewage and the like, and 2 represents an outlet for the same. The outlet 2 is shown at a higher level than the intake 1, which is a condition of affairs that is frequently encountered in practice and which requires some 85 means for lifting the sewage. For the sake of explanation I have shown in this connection portions or parts of means well known in the art for pneumatically lifting the sewage, although my invention is not necessarily 90 limited to such means. The means shown comprise a receiving-chamber 3, into which the sewage gravitates from the intake 1, a forcing-chamber 4, into which the sewage flows from the receiving-chamber by way of 95 the pipe 5, which is provided with a suitable check-valve 6, and a pipe 7, through which the sewage passes at a comparatively high velocity from the forcing-chamber to the outlet 2. The described movement of the sewage 100 from the forcing-chamber 4 through the pipe 7 is effected by the introduction into the forc-

ing-chamber of usually air under pressure, although other compressible or gaseous fluid could be employed.

8 is an air-chamber from which air is expelled, as by way of the inverted-U-shaped upwardly-extending pipe 9, into the forcing-chamber 4. The air is so expelled from the chamber 8 by the introduction into that chamber of a sufficient volume of water to expel it. Hitherto this necessary volume of water was taken by means of automatic flushing apparatus or the like from a tank into which high-pressure water flowed, and thus a material part of the potential energy or initial head of the high-pressure water was wasted at the intermediate or flush tank, and this volume of water after having accomplished its work was somewhat polluted by contact with the sewage and was wasted.

Having thus indicated certain apparatus in connection with which my invention is productive of new and useful results, I will now proceed with a description of the transformation of potential energy in accordance with my invention and in connection with the best means known to me for embodying the same, although other and equivalent means are known to me and will suggest themselves to those skilled in the art.

10 is a pumping device responding to the application of energy at high potential or pressure, as to the energy of a small volume of water at high pressure, and adapted to furnish a comparatively large volume of water or other non-compressible fluid at comparatively low pressure and to reuse the fluid. Such means are shown to comprise a water-motor-driven pump, which is an efficient piece of apparatus adapted to transform the energy of a small volume of water at high pressure or head into the energy of a large volume of water at comparatively low pressure or head without material loss, and, further, to reuse the same large volume of water, to which, if desired, a lubricant may be added. Such an apparatus is very reliable in action and does not require constant supervision or attention and will take care of itself and remain in good operative condition for long periods of time. Nevertheless use may be made of a steam or electrically driven pump for reusing the same fluid. A small volume of water at a comparatively high pressure or head is led to the apparatus 10, as by an inlet-pipe 11 and an outlet-pipe 12. This supply of water may be taken from the city mains or from other appropriate sources, and after leaving the apparatus 10 it is perfectly clean and may be used for any purpose.

There is a cistern 13, which contains a supply of water or other non-compressible fluid in volume sufficient to fill the air-chamber 8, the water-pipe 14, and the inverted-U-shaped pipe 9, and this supply of water is reused as often as required. The apparatus 10, driven by the energy of the small volume of water at high head traversing the pipes 11 and 12,

operates to lift water or other liquid from the cistern as often as necessary by way of the pipes 15 and 16 and deliver it in comparatively large volume to the tank 17, which is at a comparatively low level or head. This tank 17 may be regarded as a part common to the system which has been described as the one to which my invention is applicable. This tank 17 is equipped with an automatic flushing device, as 18, so that at appropriate intervals, depending upon the quantity of sewage to be lifted, it empties itself by way of the pipe 14 into the air-chamber 8, and thus drives out the air contained therein and effects the necessary movement of the sewage, as has been described. The pipe 14 is equipped with a vent-pipe 19.

20 is a valve which may be actuated by a float, as shown, or by hand or in any appropriate way for opening and closing the passage-way through the discharge-pipe 12, as will be described.

21 is a valved pipe that may be employed for filling or refilling the cistern 13 in order to make up for losses arising by evaporation or the like.

22 is a siphon by means of which water is withdrawn from the air-chamber 8 and returned to the cistern 13 after it has done its work in driving out the air and in preparation for its reuse. The pipe 16 extends above the top of the siphon 22, and therefore affords the necessary head for setting up its action as a siphon. The pipe 9 extends upward above the siphon 22 and, as shown, above the tank 17, so that water may not escape through it and reach the forcing-cylinder 4.

The mode of operation of the described apparatus may be stated as follows: Sewage and the like gravitates into the receiver 3, and upon reaching a predetermined level therein operates the valve 20, and thus sets the pump 10 in motion, and the latter operates to raise water from the cistern 13 into the tank 17. Of course by operating the valve 20 by hand or otherwise the whole apparatus may be caused to operate as often as required. In this way there is a step-down transformation of potential energy, and in the apparatus chosen for illustration a small volume of water at high pressure is used to drive the pump 10 and a large volume of water at comparatively low pressure or head is obtained in the tank 17. Sewage gravitates past the valve 6 and occupies the forcing-cylinder 4. When this occurs, the actions of the various parts shown are so timed that the automatic flushing or emptying device 18 permits the contents of the tank 17 to flow by way of the pipe 14 and enter the air-chamber 8 and fill it, so that air is driven from this chamber by way of the pipe 9 into the forcing-cylinder 4. The check-valve 6 prevents retrograde movement of the sewage, so that it is forced through the pipe 7 into the outlet 2 with a very rapid motion, which causes solid matter to be also discharged. In a short time the chamber 8 is

filled with water and the water rises in the pipe 22 and also in one leg of the pipe 9. However, the rise of water in the pipe 22 causes it to act like a siphon and thus remove the water from the chamber 8 and return it to the cistern 13. By reason of the height of the pipe 9 water rises only in one of its legs, and therefore does not reach the chamber 4. The receiver 3 is again filled. The automatic flushing device again operates. The described operation is repeated as often as may be necessary and without supervision of an attendant and the same water reused and returned to the cistern.

It will be obvious to those skilled in the art to which my invention appertains that modifications may be made in details without departing from the spirit thereof. Hence I do not limit myself to the precise construction and arrangement of parts hereinabove set forth, and illustrated in the accompanying drawings; but,

Having thus described the nature and objects of my invention, what I claim as new, and desire to secure by Letters Patent, is—

1. A system for raising sewage and the like comprising apparatus adapted to lift sewage and to be operated by air or similar gaseous pressure, means for transforming a small volume of water at high pressure or head into a large volume of non-compressible fluid at low pressure, and devices adapted to respond to the comparatively large volume of fluid at low pressure and to supply air or gaseous material to the first-mentioned apparatus, substantially as described.

2. A system for raising sewage and the like comprising pneumatic apparatus adapted to be operated by a comparatively large volume of non-compressible fluid at low head or pressure and to lift the sewage, and means

actuated by a small volume of water at high pressure and adapted to supply a comparatively large volume of non-compressible fluid at low pressure for operating the first-mentioned apparatus, substantially as described.

3. The combination of a forcing-cylinder and its complemental automatic flushing-tank and air-chamber and connections, a water-driven pump, connections for supplying said pump with a comparatively small volume of water at high pressure, a cistern, connections from the cistern through the pump to the tank, a siphon for emptying water from the air-chamber into the cistern, and devices for automatically regulating the supply of water at high pressure, substantially as described.

4. A system for raising sewage and the like comprising pneumatic apparatus for lifting the sewage, means for effecting circulation of the same body of non-compressible fluid, and devices operated by the circulation of the fluid and adapted to supply compressed air for working the first-mentioned apparatus, substantially as described.

5. A system for raising sewage and the like comprising pneumatic apparatus for lifting the sewage, means responding to the sewage to be lifted and constructed to effect circulation of the same body of fluid, and devices operated by the circulation of the fluid and adapted to supply compressed air for working the first-mentioned apparatus, substantially as described.

In testimony whereof I have hereunto signed my name.

ALBERT PRIESTMAN.

In presence of—

K. M. GILLIGAN,
W. J. JACKSON.